

# Evanesce Tension B Series

Slim in-ceiling electric projection screen hides perfectly into any ceiling.



## Screen Material

- CineWhite™ tensioned front projection material
- 180° wide-viewing angle and 1.1 gain
- 4K Ultra HD and Active 3D Ready
- Tab-tension cords provide uniform flatness on entire projection surface
- Black-backing and black masking borders
- Available in the following diagonal sizes:
  - 92", 100", 110" and 120" in 16:9 format

## Design and Installation

- Below and above ceiling access installation design
- Concealed in-ceiling front projection screen for multi-use rooms
- Aluminum housing with white finish (RAL9003) is slim yet strong and moisture resistant
- Integrated ceiling projection screen ships fully assembled, ready to install
- Installation kit included

## Control System

- Internal Radio Frequency/Infrared receivers with IR, RF remotes included
- Low voltage 3-way wall switch and in-wall RJ45 module included
- Standard 5-12 volt trigger to synchronize screen operation with the projector's power cycle
- RJ45 port allows 3rd party control systems integration
- Optional in-wall up/down switch (part# ZIW-W)
- Optional 5-12 volt wireless trigger

## Quality and Reliability

- ETL, FCC, CE, CB GOSTCE & ISO9001:2008



## Evanesce Tab-Tension B Series

Model	Screen Diag. & Aspect Ratio	View Height (in)	View Width (in)	View Height (cm)	View Width (cm)	N.W. (lbs.)	G.W. (lbs.)	N.W. (kgs)	G.W. (Kgs)	Packaging Dimensions (LxHxW)	Gain	Screen Material
ETB92HW2-E12	92"(16:9)	45.1	80.2	114.6	203.7	29.7	52.0	13.5	23.6	102.8"x7.5"x7.7"	1.1	CineWhite™
ETB100HW2-E12	100"(16:9)	49.0	87.2	115.2	204.9	40.8	55.9	18.5	25.3	111.0"x8.3"x7.7"	1.1	CineWhite™
ETB110HW2-E8	110"(16:9)	53.9	95.9	136.9	243.6	35.9	59.3	16.3	26.9	120.1"x7.7"x8.3"	1.1	CineWhite™
ETB120HW2-E8	120"(16:9)	58.9	104.6	138.4	245.8	37.3	59.8	16.9	27.1	125.6"x7.7"x8.1"	1.1	CineWhite™

## Evanesce Tab-Tension B Series Dimensions Table (Above ceiling)

Model	Screen Diag. & Aspect Ratio	Full Housing Length (A)	View Width (A1)	L/R Black Masking (A2)	Wright Bar Length (A3)	Case Length (A4)	A5	Overall Height (B)	View Height (B1)	Top Border (B2)	B3	Case Height (B4)	Screen Fully Deployed Height (B5)	Case Width (C)	C1	C2	C3	C4
ETB92HW2-E12	92"(16:9)	2408	2037	95	2342	2347	2377	2571	1146	305	100	95	1552	80	925	145	180	50
ETB100HW2-E12	100"(16:9)	2590	2214	95	2525	2530	2560	2670	1245	305	100	95	1650	80	925	145	180	50
ETB110HW2-E8	110"(16:9)	2810	2435	95	2745	2750	2780	2693	1370	203	100	95	1673	80	925	145	180	50
ETB120HW2-E8	120"(16:9)	3032	2657	95	2967	2972	3002	2817	1494	203	100	95	1797	80	925	145	180	50

Unit: mm

**Note: Data Error ±1".** The listed measurements are for general reference only. Please contact Elite Screens to verify product design and dimensions before attempting to integrate its products with any structural or furniture modification. Although a manufacturer may offer product advice, it may be taken or disregarded at the integrator's discretion. Elite Screens will not be held responsible or be otherwise liable for faulty installations.

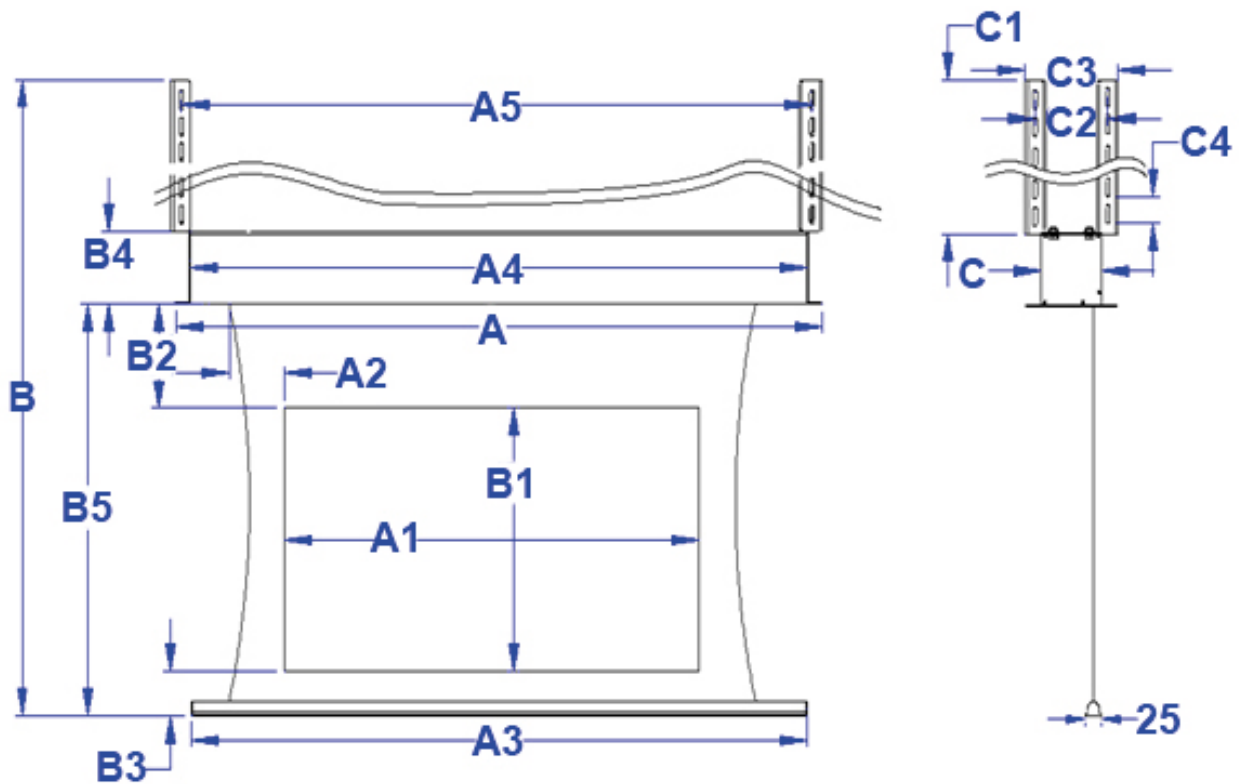

**Evanesce Tab-Tension B Series Dimensions Table (Below ceiling)**

Model	Screen Diag. & Aspect Ratio	Full Housing Length (A)	View Width (A1)	L/R Black Masking (A2)	Wright Bar Length (A3)	Case Length (A4)	A5	Overall Height (B)	View Height (B1)	Top Border (B2)	B3	Case Height (B4)	Screen Fully Deployed Height (B5)	C	C1	C2	C3
ETB92HW2-E12	92"(16:9)	2408	2037	95	2342	2347	2377	1646	1146	305	100	94	1552	110	80	120	2398
ETB100HW2-E12	100"(16:9)	2590	2214	95	2525	2530	2560	1746	1245	305	100	96	1650	110	80	120	2580
ETB110HW2-E8	110"(16:9)	2810	2435	95	2745	2750	2780	1770	1370	203	100	97	1673	110	80	120	2800
ETB120HW2-E8	120"(16:9)	3032	2657	95	2967	2972	3002	1892	1494	203	100	95	1797	110	80	120	3022

Unit: mm

**Note: Data Error ±1".** The listed measurements are for general reference only. Please contact Elite Screens to verify product design and dimensions before attempting to integrate its products with any structural or furniture modification. Although a manufacturer may offer product advice, it may be taken or disregarded at the integrator's discretion. Elite Screens will not be held responsible or be otherwise liable for faulty installations.

